

# User's Guide

---

## iPORT/AI 2™

ASCII Interface  
RS-232 to I<sup>2</sup>C Host Adapter  
with *Circuit Sense*™



---

**MCC**  
Micro Computer Control  
*Small Area Network Specialists*

[www.mcc-us.com](http://www.mcc-us.com)

# Introduction



The MCC **iPort/AI 2™** RS-232 to I<sup>2</sup>C Bus host adapter with *Circuit Sense* allows any Windows, Linux, or Mac OS X host computer to become an I<sup>2</sup>C Master or Slave device, transmitting or receiving I<sup>2</sup>C messages between the host computer and one or more I<sup>2</sup>C devices across an I<sup>2</sup>C Bus.

This user's guide describes the installation and operation of the iPort/AI 2 host adapter, and the RS-232 and I<sup>2</sup>C Bus interconnects. Also described are the iPort Utility Pack software for quick I<sup>2</sup>C Bus communication, MS.Net and LabVIEW libraries for custom software development, and other tools and applications.

A complete set of resources for the iPort/AI 2 is available at:

[www.mcc-us.com/iPortAI-2](http://www.mcc-us.com/iPortAI-2)

This product conforms to the I<sup>2</sup>C Bus specifications defined by NXP/Philips Semiconductors.

To find out more about I<sup>2</sup>C, we suggest you review our white paper "I<sup>2</sup>C Bus Technical Overview" at:

[www.mcc-us.com/I2CBusTechnicalOverview.pdf](http://www.mcc-us.com/I2CBusTechnicalOverview.pdf)

I<sup>2</sup>C is a trademark of NXP (Philips) Corporation. All trademarks acknowledged as the property of their owners.

01-NOV-2018

Copyright© 2018 by Micro Computer Control Corporation. All rights reserved. No part of this publication may be reproduced by any means without the prior written permission of Micro Computer Control Corporation, PO Box 275, Hopewell, New Jersey 08525 USA.

**DISCLAIMER:** Micro Computer Control Corporation makes no representations or warranties with respect to the contents hereof and specifically disclaims any implied warranties of merchantability or fitness for any particular purpose. Further, Micro Computer Control Corporation reserves the right to revise the product described in this publication and to make changes from time to time in the content hereof without the obligation to notify any person of such revisions or changes.

**WARNING - Life Support Applications:** MCC products are not designed for use in life support appliances, devices, or systems where the malfunction of the product can reasonably be expected to result in a personal injury.

**WARNING - Radio Frequency Emissions:** This equipment can radiate levels of radio frequency energy that may cause interference to communications equipment. Operation of this equipment may cause interference with radio, television, or other communications equipment. The user is responsible for correcting such interference at the expense of the user.

**WARNING - Electrostatic Discharge (ESD) Precautions:** Any damage caused by Electrostatic Discharge (ESD) through inadequate earth grounding is NOT covered under the warranty of this product. See the “Electrostatic (ESD) Precautions” section of this guide for more information.



**Electronic Waste Notice** - This product must NOT be thrown into general waste, but should be collected separately and properly recycled under local regulations.

Created in the United States of America

# Table of Contents

1	Overview	1
	iPort/AI 2 Product Features	2
	iPort/AI 2 Package Contents	3
	System Requirements	4
2	Interconnects	4
	RS-232 Serial Port Connector	4
	DB-25 Serial Port Pinout	4
	DB-9 Serial Port Pinout	4
	iPort Power	5
	Via the power jack	5
	Via the I <sup>2</sup> C interface connector	5
	I <sup>2</sup> C Mini Interface Connector	5
3	Hardware Configuration	6
	Circuit Sense	6
	Power Source Mode	6
	Voltage Sense Mode	6
	I <sup>2</sup> C Bus Pull-up Resistors	7
	Connecting to a Low-Voltage Target System	7
	Connecting to an SMBus Target System	7
4	ESD (Electrostatic Discharge) Precautions	8
	Host Computer Grounding	8
	Case 1 - Desktop and Single-board Computers	8
	Case 2 - Laptop Computers	9
	Grounding Solutions	9
5	Hardware Set-Up	9
	Serial Port Connection	10
	I <sup>2</sup> C Bus Connection	10
	Power Connection	10
6	Software Support	10
	I <sup>2</sup> C Bus Communication Utilities	10
	iPort Utility Pack for Windows	10
	iPort Message Center	11
	iPort Message Manager	11

iBurner I <sup>2</sup> C Bus EEPROM Programmer .....	11
I <sup>2</sup> C Bus Software Development Tools .....	11
MS.NET Class Library .....	11
LabVIEW VI Library .....	12
ASCII Command Interface .....	12
iPort/AI 2 Revision Report .....	13
Additional Information .....	13
Appendix A - I <sup>2</sup> C Connector Information .....	14
Declaration of Conformity .....	15
FCC Statement .....	15
CE Declaration of Conformity .....	15

# 1 Overview

The MCC iPort/AI 2 (#MIIC-212), RS-232 to I<sup>2</sup>C Bus Host Adapter with ASCII Interface and *Circuit Sense*, allows any PC, Host Computer, PLC, or Single Board Computer with a legacy or add-on serial port to become an I<sup>2</sup>C Master or Slave device, transmitting or receiving I<sup>2</sup>C messages between the Host Computer and one or more I<sup>2</sup>C devices across an I<sup>2</sup>C Bus.



*Circuit Sense*, our I<sup>2</sup>C Bus voltage sensing technology, allows the iPort/AI 2 to work with the latest I<sup>2</sup>C Bus devices at voltages as low as 0.5 volts.



## iPort/AI 2 Product Features

- OS Support: Windows, Linux, Mac OS X, and many more.
- Host Support: Any Computer with a legacy or add-on RS-232 Serial Port.
- High Performance Processor Increases Throughput (2x to 200x).
- External Power Jack or I<sup>2</sup>C Bus Powered (+5VDC).
- Built-in ESD, Over-voltage, and Reverse-voltage Protection.
- Switch Controlled Properties:
  - I<sup>2</sup>C Bus Power Source (5v@100ma).
  - I<sup>2</sup>C Bus Voltage Sense (0.5v to 5v, Enable or Disable).
  - I<sup>2</sup>C Bus Pull-Ups (1.8K ohm, Enable or Disable).
- Software Controlled Properties:
  - I<sup>2</sup>C Bus Master Clock Rates: 100KHz (Fixed)
  - I<sup>2</sup>C Bus General Call (Enable or Disable).
  - I<sup>2</sup>C Bus Time-Out (1000 milliseconds) (Fixed)
  - Host Communication Flow Control (XON/XOFF or RTS/CTS)
  - User Interface Echo/Prompt (Enable or Disable).
  - User Data Format (HEX or ASCII/HEX)
- Supported I<sup>2</sup>C Bus Activities:
  - Master and Slave Functions
  - Transmit, Receive, and Tx/Rx Data Functions
  - Multi-Master Arbitration Loss Detection
  - Clock-stretch Detection
  - Bus Time-Out Detection
  - 7-bit Slave Address Generation and Detection
  - Up to 32K data bytes in a single message
- Software Support:
  - Free Application Software (Master, Slave, and EEPROM Programmer).
  - Software Development Tools (MS.NET, LabVIEW, and ASCII Commands).
- Compatible with existing iPort/AI applications.
- US-FCC and EUR-CE EMC Compliant.
- RoHS/Lead-Free Compliant.

## iPort/AI 2 Package Contents

The iPort/AI 2 package includes the following items:

- iPort/AI 2, RS-232 to I<sup>2</sup>C Bus Host Adapter.
- I<sup>2</sup>C Bus Mini Clip-lead Cable (4-wire, 1 ft.).
- DB-9F to DB-25M Serial Port Adapter Cable (1 ft.).
- Global 5VDC Power Supply.
- iPort/AI 2 Quick Start Guide.
- iPort/AI 2 Travel Case.
- Online Items\*
  - iPort/AI 2 Datasheet
  - iPort/AI 2 User's Guide (this document)
  - iPort Utility Pack Software
  - Application Software.
  - Software Development Tools

(\* [www.mcc-us.com/iPortAI-2](http://www.mcc-us.com/iPortAI-2))





## System Requirements

- a. A host computer with one free legacy or add-on RS-232 port.
- b. Windows XP OS or higher to run iPort Utility Pack applications.

## 2 Interconnects

The iPort/AI 2 includes three (3) interconnections:

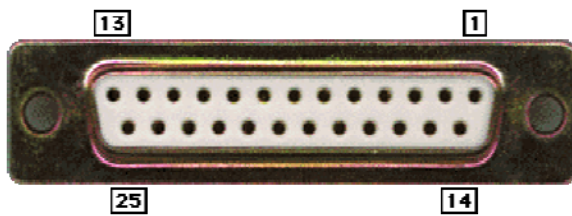

RS-232 Serial Port Connector

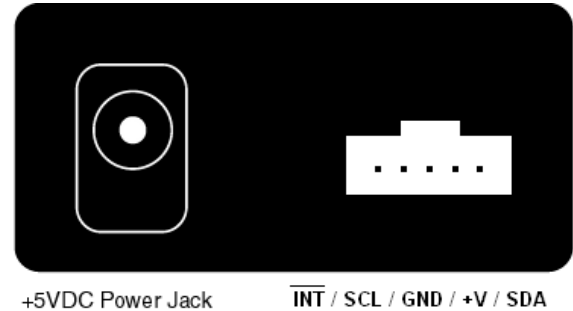

### RS-232 Serial Port Connector

The RS-232 connector provides connection from the I<sup>2</sup>C adapter to the serial port on the host computer. For computers with DB-9 connectors, use the DB-9 to DB-25 (#C9F25M1) cable provided with the adapter, or equivalent.

The I<sup>2</sup>C adapter implements the RS-232 interface using the following pins:

### DB-25 Serial Port Pinout

- DB-25 Pin 2, Transmit Data from the Host Computer to the iPort
- DB-25 Pin 3, Receive Data from the iPort to the Host Computer.
- DB-25 Pin 4, Request to Send from the Host Computer to iPort.
- DB-25 Pin 5, Clear to Send from the iPort to the Host Computer.
- DB-25 Pin 7, Ground between Host Computer and iPort

### DB-9 Serial Port Pinout

- DB-9 Pin 3, Transmit Data from the Host Computer to the iPort
- DB-9 Pin 2, Receive Data from the iPort to the Host Computer.
- DB-9 Pin 7, Request to Send from the Host Computer to iPort.
- DB-9 Pin 8, Clear to Send from the iPort to the Host Computer.

## DB-9 Pin 5, Ground between Host Computer and iPort

### iPort Power

The I<sup>2</sup>C adapter requires 50ma of REGULATED +5 volt power. This power can be supplied in one of two ways:

- Via the power jack.  
If the I<sup>2</sup>C adapter is powered via its +5VDC power jack, and the adapter is operating in power SOURCE mode, excess power is available via the +V wire in the I<sup>2</sup>C connector to power external devices.
- Via the I<sup>2</sup>C interface connector.  
If 50ma of regulated +5V power is available in the target system, and the adapter is operating in power SOURCE mode, the I<sup>2</sup>C adapter can be powered via the +V wire in I<sup>2</sup>C interface connector.

### I<sup>2</sup>C Mini Interface Connector

The iPort/AI 2 I<sup>2</sup>C Bus host adapter includes a five wire (1x5) 2.54 mm (.100"), positive locking, shrouded header receptacle connector (see Appendix A) for interfacing to an external I<sup>2</sup>C Bus. Interface lines provided include:

- I<sup>2</sup>C Clock (SCL)
- I<sup>2</sup>C Data (SDA)
- /INT (Not Used)
- Ground
- +V (optional)

Minimum wiring for I<sup>2</sup>C Bus communications include I<sup>2</sup>C Bus Clock, Data, and Ground. Use of the +V wire in the I<sup>2</sup>C Interface connector are user optional.

NOTE: See the Hardware Configuration section below for additional information on configuring the I<sup>2</sup>C Bus interface.

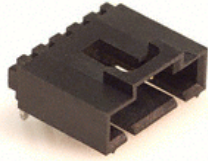

I<sup>2</sup>C Bus Mini Interface Receptacle

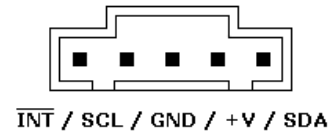

Mini Interface Receptacle Pinout

I<sup>2</sup>C Bus Mini-Clip-Lead cables are available to connect the iPort/AI 2 adapter to a target system. Each clip-lead is identified (White=C=SCL, Red=V=+V, Green=D=SDA, Black=G=Ground).

I<sup>2</sup>C Bus Mini-Interface cables with two Mini Interface plugs are also available to connect the I<sup>2</sup>C adapter to an external I<sup>2</sup>C Bus.

### 3 Hardware Configuration

#### *Circuit Sense™*

The iPort/AI 2 includes MCC's *Circuit Sense* technology. Circuit Sense allows the I<sup>2</sup>C interface +V wire can operate in two modes, Power Source Mode and Voltage Sense Mode. Mode selection is controlled by the MODE slide switch on the side of the unit enclosure.

**Power Source Mode** - The +V wire can supply power (5v @ 100 mA) V<sub>cc</sub> to an external I<sup>2</sup>C Bus system. In Power Source Mode, the voltage of the iPort/AI 2 SCL, and SDA internal pull-ups, if enabled, and Voltage Sense circuit (0.3V<sub>cc</sub> Low<sub>MAX</sub>, 0.7V<sub>cc</sub> High<sub>MIN</sub>) is connected to the adapter's +5v power supply. (Use of the +V wire in Power Source Mode is user optional).

Power Source Mode is similar to the standard mode of operation on earlier versions of MCC I<sup>2</sup>C Bus host adapters.

**Voltage Sense Mode** - The +V wire is connected to the external I<sup>2</sup>C Bus system pull-up supply voltage (0.5v to 5v) V<sub>cc</sub>, and automatically adjusts iPort/AI 2 SCL, SDA, and /INT Voltage Sense circuit levels to match (0.3V<sub>cc</sub> Low<sub>MAX</sub>, 0.7V<sub>cc</sub>

High<sub>MIN</sub>). In Voltage Sense Mode, the voltage of the iPort/AI 2 SCL, SDA, and /INT internal pull-ups, if enabled, is equal to the external voltage (Vcc) applied to the +V wire. (Use of the +V wire in Voltage Sense Mode is required).

## I<sup>2</sup>C Bus Pull-up Resistors

I<sup>2</sup>C Bus systems are based on open-collector technology requiring pull-up devices on each signal wire (SCL, SDA, /INT). These pull-up devices usually take the form of pull-up resistors connected to bus power.

The I<sup>2</sup>C adapter includes a PULL-UPS slide switch used to enable or disable internal 1.8K ohm pull-up resistors attached to the SCL, SDA, and /INT lines. Every I<sup>2</sup>C Bus system must have at least one pull-up on the signal lines. In some cases, the pull-ups may be present in the external I<sup>2</sup>C Bus circuit. Use this switch to configure the pull-up resistors for your system.

## Connecting to a Low-Voltage Target System

If you are connecting the I<sup>2</sup>C adapter to a low-voltage (<5v) target system, you should follow these steps BEFORE applying power:

- Using the adapter MODE slide switch, put the adapter in Sense Mode.
- If your target system does NOT supply I<sup>2</sup>C Bus pull-ups, use the adapter PULL-UPS slide switch to enable the adapter's internal 1.8K ohm pull-ups.
- Connect the I<sup>2</sup>C connector +V wire to the target system I<sup>2</sup>C Bus power. The I<sup>2</sup>C adapter will be powered from its own +5V power supply, and adapters pull-ups, if enabled, and Voltage Sense circuit will be powered by the target system's low-voltage power supply.

## Connecting to an SMBus Target System

If you are connecting the I<sup>2</sup>C adapter to a SMBus target system, you should follow these steps BEFORE applying power:

- Shut off the I<sup>2</sup>C adapter's internal pull-ups (See Pull-up Resistor section).
- Use external SMBus rated (approx. 15k ohm) pull-up resistors. These pull-ups may already be present in the target system.

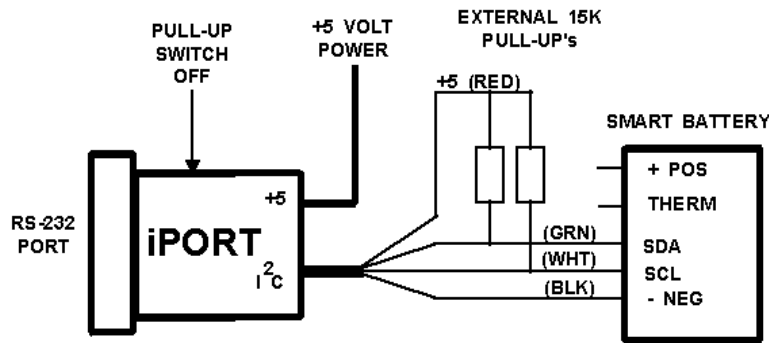

- Visit the I<sup>2</sup>C .vs. SMBus FAQ page ([www.mcc-us.com/I2CSMBusFAQ.htm](http://www.mcc-us.com/I2CSMBusFAQ.htm)).
- See the SMBus Specification for additional details.

**Special Note for SMBus Users:** MCC's I<sup>2</sup>C adapters are designed to be I<sup>2</sup>C Bus compatible, not SMBus compatible. Some features of the SMBus protocol not supported include time-outs, device reset, and Packet Error Check byte processing. The non-supported SMBus features may, or may not, permit the use of the I<sup>2</sup>C adapter in your SMBus application. Consult the MCC FAQ web page and SMBus Specification for details.

#### 4 ESD (Electrostatic Discharge) Precautions

Electrostatic discharge is defined as the transfer of charge between bodies at different electrical potentials. Electrostatic discharge can change the electrical characteristics of a semiconductor device, degrading or destroying it. Electrostatic discharge also may upset the normal operation of an electronic system, causing equipment malfunction or failure.

When connecting the I<sup>2</sup>C adapter to a host computer and a target system, extreme care must be taken to avoid electrostatic discharge. Failure to follow ESD protection procedures when using the I<sup>2</sup>C adapter could damage the host computer, I<sup>2</sup>C adapter, or the target system, and void product warranty coverage.

#### Host Computer Grounding

Case 1 - Desktop and Single-board Computers. The chassis on a desktop or single-board host computer must be connected to earth ground to comply with safety regulations. If the computer chassis is NOT connected to earth ground for some reason (i.e., use of a two-prong power mains plug), the host computer power

supply ground will float to some unknown voltage potential.

Case 2 - Laptop Computers. Laptop computers present special ESD problems. Most laptop computers use an external double-insulated mains power supply which is NOT connected to the mains earth ground. This means that the laptop chassis is floating at some unknown voltage potential.

In either case, upon connection to the I<sup>2</sup>C adapter and the target system, the host computer will discharge energy through its RS-232 port to the I<sup>2</sup>C adapter, and on to the target system. This discharge could damage the host computer, I<sup>2</sup>C adapter, and the target system.

## Grounding Solutions

To avoid damage to the host computer, I<sup>2</sup>C adapter, or target system, follow these instructions:

- Wear an earth grounded wrist strap, or discharge any static charge build-up, when handling the I<sup>2</sup>C adapter or any target system devices.
- Ensure that both the host computer and target system are connected to a common earth ground point.
- Make sure that all interconnections are made BEFORE applying power to the host computer, I<sup>2</sup>C adapter, and target system.
- If you are using a laptop computer or host computer that is NOT connected to mains earth ground, make a hard-wired connection from the host computer (i.e., RS-232 port D-connector shell) and the target system ground connector to a common earth ground point.
- Avoid plugging and unplugging system components while the host computer or target system is powered.
- Ensure that any devices connected to the target system are properly grounded to the common earth ground point.
- If unsure how to properly ground system components, seek electrical expert help.

**WARNING:** Any damage caused by Electrostatic Discharge (ESD) through inadequate earth grounding is NOT covered under the warranty of this product.

## 5 Hardware Set-Up

This section provides information on connecting the I<sup>2</sup>C adapter to your host computer and I<sup>2</sup>C Bus target system.

## Serial Port Connection

Attach the I<sup>2</sup>C adapter to a free legacy or add-on RS-232 port on your host computer. If your RS-232 port has a DB9 connector, use DB-9F to DB-25M serial port cable included with the I<sup>2</sup>C adapter.

## I<sup>2</sup>C Bus Connection

Connect the I<sup>2</sup>C Bus mini clip-lead cable to the I<sup>2</sup>C adapter and your I<sup>2</sup>C device. MCC also offers an I<sup>2</sup>C mini interface cables that are compatible with our adapters. You may not need to, or want to, connect the +V wire to your target system. Refer to the “+5VDC Power Jack” and “Hardware Configuration” sections for details on pull-up resistors and connecting the optional +V wire.

## Power Connection

Connect I<sup>2</sup>C adapter power via the power jack or I<sup>2</sup>C Bus connector. See “+5VDC Power Jack” section for details.

If you have any questions on I<sup>2</sup>C adapter setup and configuration, please visit our FAQ Page (<http://www.mcc-us.com/faq.htm>) or contact our technical support team ([support@mcc-us.com](mailto:support@mcc-us.com)).

## 6. Software Support

MCC offers the following categories of I<sup>2</sup>C Bus software support:

### I<sup>2</sup>C Bus Communication Utilities

#### iPort Utility Pack for Windows

The iPort Utility Pack for Windows provides a quick-start to I<sup>2</sup>C Bus communications. The Utility Pack includes two Windows-based application that will help you get started sending and receiving I<sup>2</sup>C Bus messages quickly and easily.

## iPort Message Center

iPort Message Center is a bus master application with a spreadsheet-like user interface. Each row in the spreadsheet represents a single I<sup>2</sup>C Bus message. A message can transmit data to a specified slave device, or read data from a specified slave device. Received data is automatically displayed in the spreadsheet.

Message options include repeated-start, and a time delay after each message. One or more messages in the spreadsheet are transmitted in sequence, and can auto-repeat at the completion of the last message.

## iPort Message Manager

iPort Message Manager is a bus master/slave application that can master transmit, master receive, slave transmit, and slave receive I<sup>2</sup>C Bus messages. Message options include master transmit and transmit/receive, and auto-repeat

## iBurner I<sup>2</sup>C Bus EEPROM Programmer

iBurner is our I<sup>2</sup>C Bus EEPROM Programmer software package for Windows. With iBurner, you can quickly and easily blank-check, program, read, and verify a wide variety of I<sup>2</sup>C Bus EEPROMs. iBurner also supports scripting, allowing EEPROM programing serialization and automation.

## I<sup>2</sup>C Bus Software Development Tools

MCC provides three methods for creating custom application software for ASCII Interface I<sup>2</sup>C Bus Adapters:

### MS.NET Class Library

The MS.NET Class Library provides a comprehensive set of tools for the creation of robust I<sup>2</sup>C Bus applications. Included are Constructors, Methods, Properties, Events, Enumerations, and SampleCode for Visual Basic.NET, Visual C#, Visual C++, Visual J#, and LabVIEW.



## LabVIEW VI Library

The LabVIEW VI Library provides a complete set of low-level, mid-level, and high-level Virtual Instruments (Vis) for the LabVIEW developer. Included are VIs for establishing a connection to the Adapter, performing I<sup>2</sup>C Bus Master and Slave operations, and Sample LabVIEW applications.

## ASCII Command Interface

The ASCII Command Interface provides a direct low-level ASCII command application program interface to the I<sup>2</sup>C Bus Adapter. ASCII commands can be accessed from a terminal emulation program running on the host computer, or from an application program using host computer operating system serial port functions.

iPort/AI 2 software support and more is available at:

[www.mcc-us.com/iPortAI-2](http://www.mcc-us.com/iPortAI-2)

## iPort/AI 2 Revision Report

This section defines revisions and changes made to the iPort/AI 2 interface:

Revision: 1.00

### 7. Initial Release

#### Additional Information

For additional information on the I<sup>2</sup>C Bus, please refer to the following:

“What is I<sup>2</sup>C?”

[www.mcc-us.com/I2CBusTechnicalOverview.pdf](http://www.mcc-us.com/I2CBusTechnicalOverview.pdf)

“Frequently Asked Questions (FAQ)”

[www.mcc-us.com/faq.htm](http://www.mcc-us.com/faq.htm)

"The I<sup>2</sup>C and How to Use It"

[www.mcc-us.com/i2chowto.htm](http://www.mcc-us.com/i2chowto.htm)

## Appendix A - I<sup>2</sup>C Connector Information

### I<sup>2</sup>C Bus Interface Connector and Plug Information

The iPort/AI 2 uses the following 1x5 2.54 mm (.100") pitch, 0.64 mm (.025") square pin, header and plug assemblies for the I<sup>2</sup>C Bus interface.

#### I<sup>2</sup>C Header Receptacle

Molex C-Grid® SL™ 70553 Header

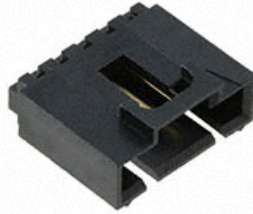

Molex Part # 70553-0004

#### I<sup>2</sup>C Plug Housing

Molex C-Grid® SL™ 70066 Crimp Housing

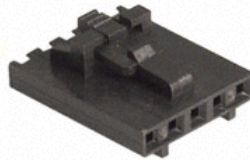

Molex Part # 50-57-9405

Molex C-Grid® SL™ 70058 Crimp Terminal



Molex Part # 16-02-0102

iPort/AI 2 I<sup>2</sup>C cables and other accessories are available online at:

[www.shop-mcc-us.com](http://www.shop-mcc-us.com)

## **Declaration of Conformity**

### **FCC Statement**

#### **DECLARATION OF CONFORMITY WITH FCC RULES FOR ELECTROMAGNETIC COMPATIBILITY**

We, Micro Computer Control Corporation, of 83 Princeton Avenue #1D / PO Box 275, Hopewell, New Jersey 08525 USA, declare under our sole responsibility that the product:

**iPort/AI 2 (#MIIC-212) and iPort/AFM 2 (#MIIC-213)**

to which this declaration relates:

Complies with Part 15 of the FCC Rules. Operation is subject to the following two conditions; (1) this device may not cause harmful interference, and (2) this device must accept any interference received, including interference that may cause undesired operation.

Test Laboratory Information:

MET Laboratories, Inc.

Test Report Number: EMC88332-FCC

Test Report Date: January 27, 2016

Technical file held by: Micro Computer Control Corporation, 83 Princeton Avenue #1D / PO Box 275, Hopewell, New Jersey 08525 USA, or its applicable authorized distributor or representative.

### **CE Declaration of Conformity**

We, Micro Computer Control Corporation, of 83 Princeton Avenue #1D / PO Box 275, Hopewell, New Jersey 08525 USA, declare under our sole responsibility that the **iPort/AI 2 (#MIIC-212)** and **iPort/AFM 2 (#MIIC-213)**, to which this declaration relates, is in conformity with EMC Emissions Standard for Information Technology Equipment EN55022:2010, and EMC Immunity Standard for Electrical Equipment for Measurement, Control and Laboratory Use EN 61326-1: 2013.

Test Laboratory Information:

CLASS Industries, Ltd.

Test Report Number: CI06074

Test Report Date: November 3, 2015

Technical file held by: Micro Computer Control Corporation, 83 Princeton Avenue #1D / PO Box 275, Hopewell, New Jersey 08525 USA, or its applicable authorized distributor or representative

**[www.mcc-us.com](http://www.mcc-us.com)**