

User's Guide

I²C Bus Host Adapter Variable Clock Rate

with iPort Utility Pack Software



www.mcc-us.com

Introduction

The MCC Variable Clock Rate Host Adapter (#MIIC-201V) is a special version of our iPort Windows to I²C Host Adapter. In addition to allowing a PC to become an I²C Master or Slave device, the Variable Clock Rate adapter supports user selectable I²C Bus master clock rates of 451 Hz to 57 KHz, making this adapter suitable for special situations requiring low I²C Bus clock rates.

This user's guide describes the installation and operation of the Variable Clock Rate adapter and the iPort Utility Pack Software for Windows.

Are you new to I²C? Want to know more? We suggest you review "What is I²C?" at www.mcc-us.com/I2CBusTechnicalOverview.pdf.

MCC products use Philips components and are licensed to use the I²C Bus.

"Purchase of Philips I²C components conveys a license under the Philips' I²C patent to use the components of the I²C system, provided the system conforms to the I²C specifications defined by Philips."

I²C is a trademark of Philips Corporation.

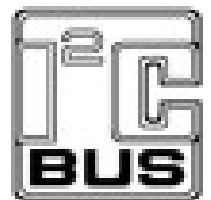

29-SEPT-04

Copyright© 2004 by Micro Computer Control Corporation. All rights reserved. No part of this publication may be reproduced by any means without the prior written permission of Micro Computer Control Corporation, PO Box 275, Hopewell, New Jersey 08525 USA.

DISCLAIMER: Micro Computer Control Corporation makes no representations or warranties with respect to the contents hereof and specifically disclaims any implied warranties of merchantability or fitness for any particular purpose. Further, Micro Computer Control Corporation reserves the right to revise the product described in this publication and to make changes from time to time in the content hereof without the obligation to notify any person of such revisions or changes.

WARNING - Life Support Applications: MCC products are not designed for use in life support appliances, devices, or systems where the malfunction of the product can reasonably be expected to result in a personal injury.

WARNING - Radio Frequency Emissions: This equipment can radiate levels of radio frequency energy that may cause interference to communications equipment. Operation of this equipment may cause interference with radio, television, or other communications equipment. The user is responsible for correcting such interference at the expense of the user.

WARNING - Electrostatic Discharge (ESD) Precautions: Any damage caused by Electrostatic Discharge (ESD) through inadequate earth grounding is NOT covered under the warranty of this product. See the “Electrostatic (ESD) Precautions” section of this guide for more information.

Printed in the United States of America

Table of Contents

Part 1 - I²C Bus Host Adapter with Variable Clock	1
1 Overview	2
Variable Clock Rate Adapter	2
iPort Utility Pack Software	2
iPort Software Development Kit for Windows	2
Packing Slip	3
System Requirements	3
2 Interconnects	3
RS-232 Serial Port Connector	3
DB-25 Serial Port Pinout	4
DB-9 Serial Port Pinout	4
+5VDC Power Jack	4
I ² C Interface Connector	4
3 Hardware Configuration	5
Pull-up Resistors	5
Connecting to a 3.3v System	5
Connecting to an SMBus System	6
4 ESD (Electrostatic Discharge) Precautions	6
Host Computer Grounding	7
Grounding Solutions	7
5 Hardware Set-Up	8
Part 2 - iPort Utility Pack for Windows	9
1 iPort Utility Pack for Windows	11
iPort Message Center	11
iPort Message Manager	12
2 System Requirements	13
3 iPort Utility Pack Installation	13
Installing from CD	13

Installing from the Web	13
4 iPort Message Center	14
Message Center Operations	15
Starting the Message Center	15
Selecting the Adapter	15
Select the Communications Port	16
Options Menu	16
Establish Adapter Communications Link	16
Entering or Editing I ² C Messages	16
Set I ² C Address	17
Set Message Read/Write Direction	17
Specify Repeated Start Messages	17
Set Time Delay	18
Specify Write Data or Read Byte Count	18
Inserting and Deleting Messages	19
Saving or Loading Message Lists	19
Send the Message List	19
Special Event Handling	19
Slave Not Acknowledging	20
Command Line Arguments	21
Set Adapter Type	22
Set RS-232 Communication Port	22
Set RS-232 Baud Rate	22
Set I ² C Bus Clock Rate	22
Enable /INT Signal Monitor	23
Stop On Busy	23
Stop On Arbitration Loss	23
Stop On Slave Negative Acknowledgment	23
Beep On Busy	23
Beep On Arbitration Loss	24
Beep On Slave Negative Acknowledgment	24
Beep On /INT Assert	24
Load I ² C Message List File	24
Saved I ² C Message List File	25
Auto Open	25
Auto Send	25
Auto Exit	25
5 iPort Message Manager	26

Message Manager Operations	27
Starting the Message Manager	27
Select the Adapter	27
Establish Adapter Communications Link	28
Basic Setup	28
Advanced Setup	29
Adapter's Own I ² C Slave Address	29
General Call Enable	29
I ² C Bus Master Bit Rate	29
I ² C Bus Time-Out	29
Enable INT Signal Monitor	29
Diagnostic Setup	30
Log File Level	30
Log File Name	30
Log File Size	30
Sending I ² C Messages	31
Master Operations	31
Specifying the Destination Address	31
Repeated Start Messages	31
Auto Repeat	31
Master Transmitting Data	32
Specifying Master Tx Message Bytes	32
Sending Master Transmit Messages	33
Master Receive Data	33
Specifying Data to Read	33
Negative Acknowledge Last Byte	33
Master Transmit and Receive	34
Slave Operations	34
Slave Transmit Data	34
Slave Receive Data	34
6 Uninstalling iPort Utility Pack	34
Additional Information	35
Appendix A - I²C Connector Information	36

Part 1

I²C Bus Host Adapter with Variable Clock

User's Guide

Model: MIIC-201V

1 Overview

The MCC Variable Clock Rate I²C Bus Host Adapter (#MIIC-201V), when used with appropriate Windows application software, allows a PC to become an I²C Master or Slave device, transmitting or receiving I²C messages between the PC and one or more I²C devices across an I²C Bus. The Variable Clock adapter also supports user selectable I²C Bus master clock rates of 451 Hz to 57 KHz, making this adapter suitable for special situations requiring low clock rates.

Product Features:

- Turn your Windows-Based PC's RS-232 Serial Port into an I²C Port.
- Supports Bus Master and Slave, Transmit and Receive Operations.
- Compatible with 3.3V to 5V I²C at user selectable bit rates of 451 Hz to 57 KHz.
- Get on the I²C Bus in Seconds. Includes our free I²C Message Manager and Message Center Windows Applications.
- Build your own custom I²C applications with our optional iPort Software Development Kit for Windows.

The I²C adapter system consists of the following components:

1.1 Variable Clock Rate Adapter

This adapter plugs into an RS-232 Port on a Windows-based PC and generates I²C Bus signals.

1.2 iPort Utility Pack Software

This free software package, includes the iPort Message Center and Message Manager applications to help you easily send and receive I²C Bus messages.

1.3 iPort Software Development Kit for Windows

This optional software package includes, the iPort DLL (Dynamic Linked Library), a programmer's guide, and sample programs. This package is needed if you are developing a custom Windows software application for the Variable Clock adapter.

1.4 Packing Slip

This package includes the following items:

- Variable Clock Rate I²C Host Adapter (#MIIC-201V).
- I²C Interface Cable.
- RS-232 Serial Port Cable, 9F/25M.
- Variable Clock Rate User's Guide.
- iPort Utility Pack for Windows software.
- Power Supply.

1.5 System Requirements

- a. Host computer with Windows 95 OS or higher.
- b. 1 free RS-232 Serial Port.

2 Interconnects

The I²C Bus Host Adapter includes three interconnections:

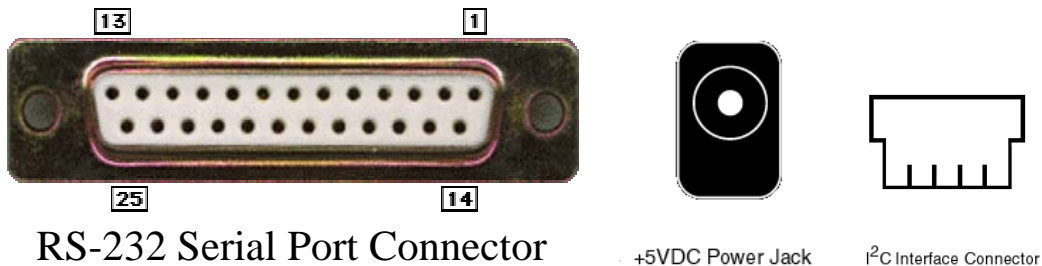

2.1 RS-232 Serial Port Connector

The RS-232 connector provides connection from the I²C adapter to the serial port on the host PC. For computers with DB-9 connectors, use the DB-9 to DB-25 (#C9F25M1) cable provided with the adapter, or equivalent.

The I²C adapter implements the RS-232 interface using the following pins:

2.1.1 DB-25 Serial Port Pinout

DB-25 Pin 2, Transmit Data from the Host Computer to the iPort

DB-25 Pin 3, Receive Data from the iPort to the Host Computer.

DB-25 Pin 4, Request to Send from the Host Computer to iPort.

DB-25 Pin 5, Clear to Send from the iPort to the Host Computer.

DB-25 Pin 7, Ground between Host Computer and iPort

2.1.2 DB-9 Serial Port Pinout

DB-9 Pin 3, Transmit Data from the Host Computer to the iPort

DB-9 Pin 2, Receive Data from the iPort to the Host Computer.

DB-9 Pin 7, Request to Send from the Host Computer to iPort.

DB-9 Pin 8, Clear to Send from the iPort to the Host Computer.

DB-9 Pin 5, Ground between Host Computer and iPort

2.2 +5VDC Power Jack

The I²C adapter requires 50ma of REGULATED +5 volt power. This power can be supplied in one of two ways:

- Via the power jack.

If the I²C adapter is powered via its +5VDC power jack, excess power is available via the +5V wire in the I²C connector to power external devices.

- Via the I²C interface connector.

If 50ma of regulated +5V power is available in the target system, the I²C adapter can be powered via the +5V wire in the I²C interface connector.

2.3 I²C Interface Connector

The I²C adapter includes a four wire, positive locking, modular receptacle connector (see Appendix A) for interfacing to an external I²C Bus. Lines provided include I²C Clock (SCL), I²C Data (SDA), Ground, and +5VDC.

Use of the +5V wire is optional. Connect this wire to the target system to power the I²C adapter and the target system from a common regulated 5V power supply.

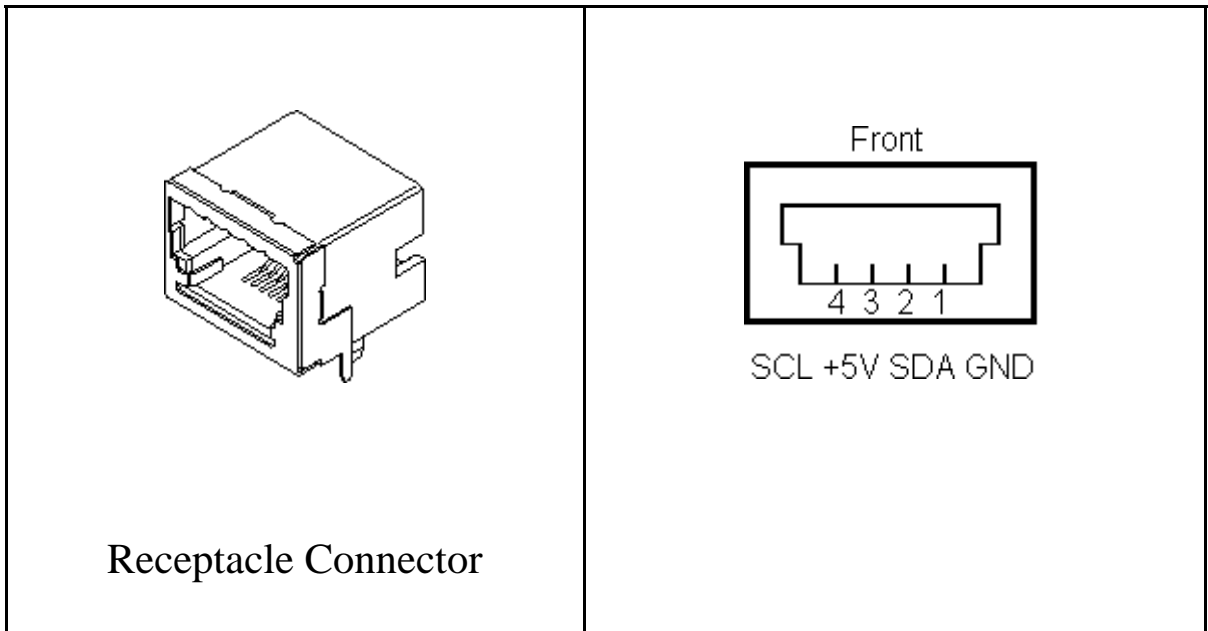

An I²C Interface Cable (White=SCL, Red=+5VDC, Green=SDA, Black=Ground) is provided to connect to an external I²C Bus. Since there is no standard I²C Bus connector, you may want to cut off one end of the cable and add a connector compatible with your target system.

Additional I²C Interface Cables (4 ft., 8ft., or 16 ft.), and modular connectors are available from MCC. Clip Lead cables are also available. (see Appendix A)

3 Hardware Configuration

3.1 Pull-up Resistors

The I²C adapter includes a slide switch used to enable or disable internal +5VDC I²C Bus 1.8K ohm pull-up resistors attached to the SCL and SDA lines. Every I²C Bus system must have at least one pull-up on the SCL and SDA lines. Use this switch to configure the pull-up resistors for your system.

3.2 Connecting to a 3.3v System

If you are connecting the I²C adapter to a 3.3 volt target system, you should follow these steps BEFORE applying power:

- Shut off the I²C adapter's internal pull-ups (See Pull-up Resistor section). Use external pull-ups to the target system's 3.3V power. These pull-ups may already

be present in the target system.

- Disconnect the I²C connector +5V wire from the target system. The I²C adapter will be powered from its own +5V power supply, and the target system will be powered by its own 3.3V power supply.

The I²C adapter is a 5-volt device. Any signal above 3.3V on the SCL and SDA lines is high enough for the adapter to see a Logical 1.

3.3 Connecting to an SMBus System

If you are connecting the I²C adapter to a SMBus target system, you should follow these steps BEFORE applying power:

- Shut off the I²C adapter's internal pull-ups (See Pull-up Resistor section).
- Use external SMBus rated (approx. 15k ohm) pull-up resistors. These pull-ups may already be present in the target system.
- Visit the I²C .vs. SMBus FAQ page (www.mcc-us.com/I2CSMBusFAQ.htm).
- See the SMBus Specification for additional details.

Special Note for SMBus Users: MCC's I²C adapters are designed to be I²C Bus compatible, not SMBus compatible. Some features of the SMBus protocol not supported include time-outs, device reset, and Packet Error Check byte processing. The non-supported SMBus features may, or may not, permit the use of the I²C adapter in your SMBus application. Consult the MCC FAQ web page and SMBus Specification for details.

4 ESD (Electrostatic Discharge) Precautions

Electrostatic discharge is defined as the transfer of charge between bodies at different electrical potentials. Electrostatic discharge can change the electrical characteristics of a semiconductor device, degrading or destroying it. Electrostatic discharge also may upset the normal operation of an electronic system, causing equipment malfunction or failure.

When connecting the I²C adapter to a host computer and a target system, extreme care must be taken to avoid electrostatic discharge. Failure to follow ESD protection procedures when using the I²C adapter could damage the host computer, I²C adapter, or the target system, and void product warranty coverage.

4.1 Host Computer Grounding

Case 1 - Desktop and Single-board Computers. The chassis on a desktop or single-board host computer must be connected to earth ground to comply with safety regulations. If the computer chassis is NOT connected to earth ground for some reason (i.e., use of a two-prong power mains plug), the host computer power supply ground will float to some unknown voltage potential.

Case 2 - Laptop Computers. Laptop computers present special ESD problems. Most laptop computers use an external double-insulated mains power supply which is NOT connected to the mains earth ground. This means that the laptop chassis is floating at some unknown voltage potential.

In either case, upon connection to the I²C adapter and the target system, the host computer will discharge energy through its RS-232 port to the I²C adapter, and on to the target system. This discharge could damage the host computer, I²C adapter, and the target system.

4.2 Grounding Solutions

To avoid damage to the host computer, I²C adapter, or target system, follow these instructions:

- Wear an earth grounded wrist strap, or discharge any static charge build-up, when handling the I²C adapter or any target system devices.
- Ensure that both the host computer and target system are connected to a common earth ground point.
- Make sure that all interconnections are made BEFORE applying power to the host computer, I²C adapter, and target system.
- If you are using a laptop computer or host computer that is NOT connected to mains earth ground, make a hard-wired connection from the host computer (i.e., RS-232 port D-connector shell) and the target system ground connector to a common earth ground point.
- Avoid plugging and unplugging system components while the host computer or target system is powered.
- Ensure that any devices connected to the target system are properly grounded to the common earth ground point.
- If unsure how to properly ground system components, seek electrical expert help.

WARNING: Any damage caused by Electrostatic Discharge (ESD) through inadequate earth grounding is NOT covered under the warranty of this product.

5 Hardware Set-Up

1. Attach the I²C adapter to a free RS-232 port on your host computer. If your RS-232 port has a DB9 connector, use DB-9F to DB-25M serial port cable included with the I²C adapter.
2. Connect the I²C Bus cable to the I²C adapter and your I²C device. If your device does not have the matching I²C connector, you can cut the end of the cable and attach the individual wires via any appropriate connector (See the “I²C Interface Connector” section for details). MCC also offers an I²C clip-lead cable (#CABCL) that is compatible with our adapters. You may not need to, or want to, connect the +5V wire to your target system. Refer to the “+5VDC Power Jack” and “Hardware Configuration” sections for details on pull-up resistors and connecting the optional +5V wire.
3. Connect I²C adapter power via the power jack or I²C Bus connector. See “+5VDC Power Jack” section for details.

If you have any questions on I²C adapter setup and configuration, please contact our technical support department via our web site.

Part 2

iPort Utility Pack for Windows V5.2

1 iPort Utility Pack for Windows

The iPort Utility Pack for Windows is your express lane to I²C Bus communications. The Utility Pack includes two (2) Windows-based applications (Message Center and Message Manager) that will help you get started sending and receiving I²C Bus messages quickly and easily.

1.1 iPort Message Center

The iPort Message Center, our most popular application, operates with all versions of our I²C Bus Host Adapters. With the Message Center, you can create, save, and automatically execute scripts of I²C Bus messages. I²C Bus message activity includes:

- Master Transmit
- Master Receive

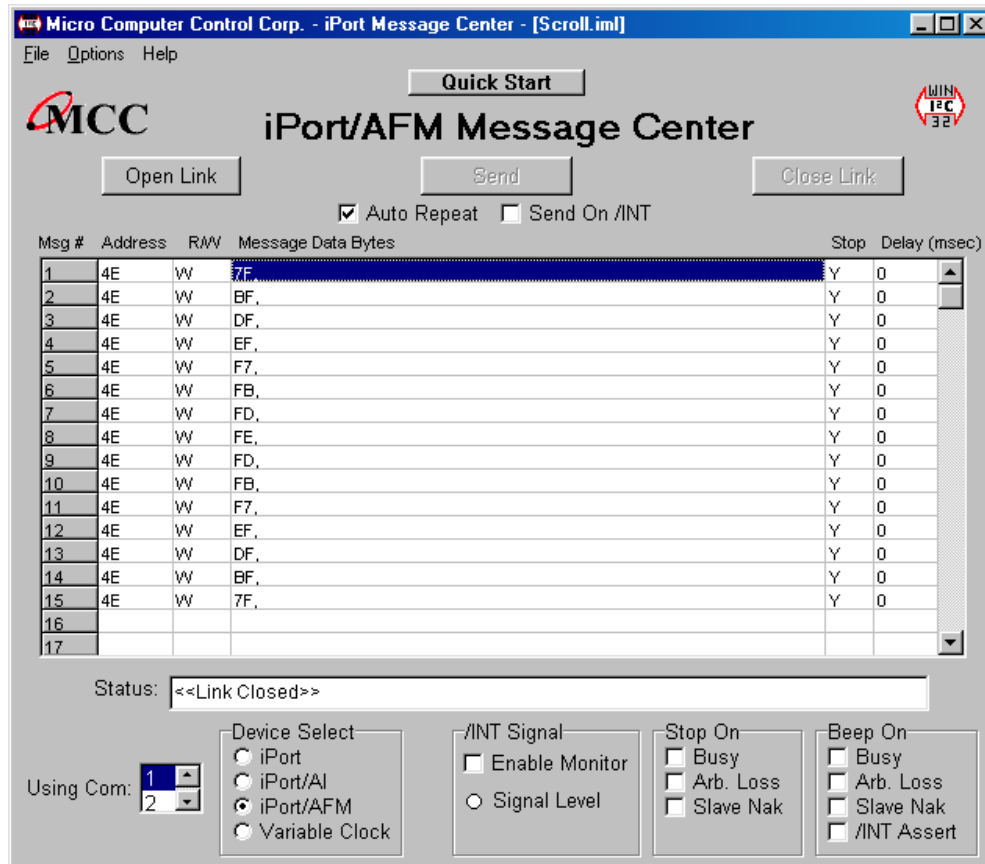

1.2 iPort Message Manager

The iPort Message Manager operates with all versions of our I²C Bus Host Adapters. Using the Message Manager, you can perform all four (4) modes of I²C Bus message activity, including:

- Master Transmit
- Master Receive
- Slave Transmit
- Slave Receive

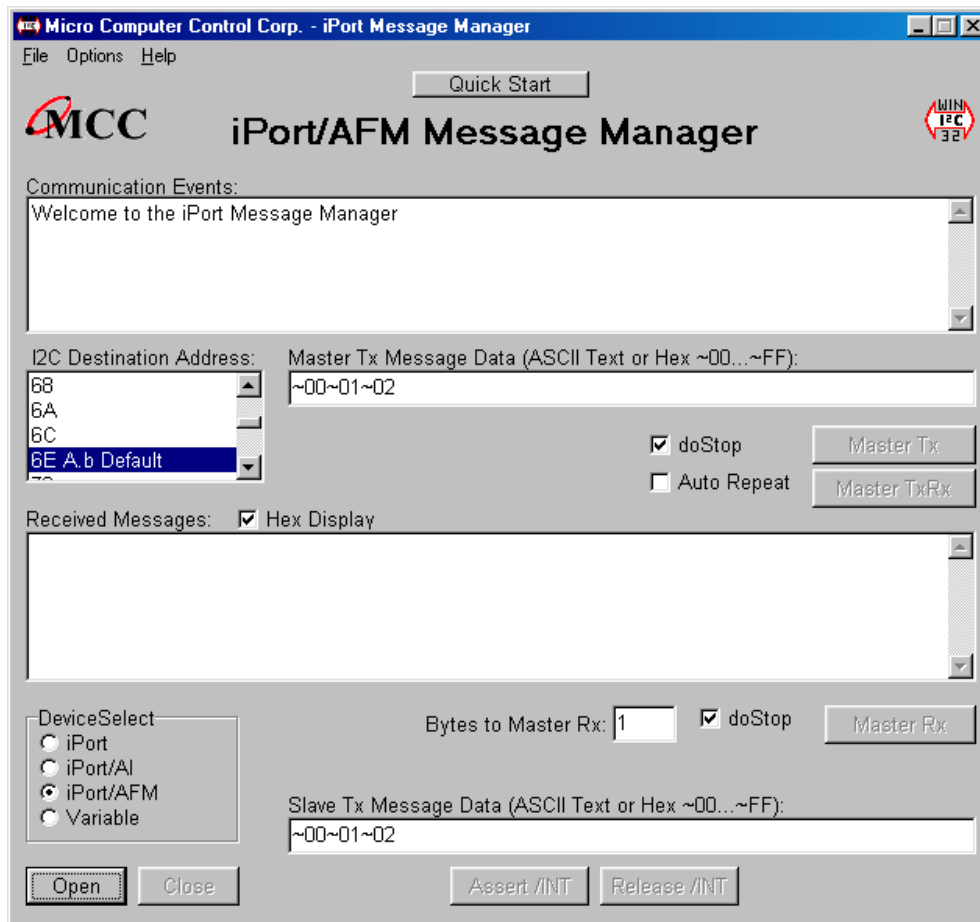

2 System Requirements

One of the following MCC I²C Bus adapters:

1. iPort (#MIIC-201) Windows to I²C Bus Host Adapter.
2. I²C Bus Host Adapter Variable Clock Rate (#MIIC-201-V).
3. iPort/AI (#MIIC-202) RS-232 to I²C Bus Host Adapter with ASCII Interface
4. iPort/AFM (#MIIC-203) RS-232 to I²C Bus Host Adapter with ASCII Fast Mode Interface.

Windows 95 OS or higher.

1 free RS-232 Serial Port.

3 iPort Utility Pack Installation

3.1 Installing from CD

1. Insert a software distribution CD into your CD drive.
2. If the install program does not start automatically, select Start*Run and type "D:SETUP.EXE." Click OK.
3. Follow instructions on screen.

3.2 Installing from the Web

Visit MCC's web site (www.mcc-us.com), and click on the Upgrades/Updates link.

- 1 Click to download the .ZIP file.
- 2 Unzip the downloaded file, storing the files in a temporary folder.
- 3 Click on "Setup.exe."
- 4 Follow the instructions on screen.

4 iPort Message Center

The iPort Message Center supports I²C Master Transmit and Master Receive activities for all MCC I²C Bus host adapters. With this program you can create, save, and execute scripts of I²C Master messages.

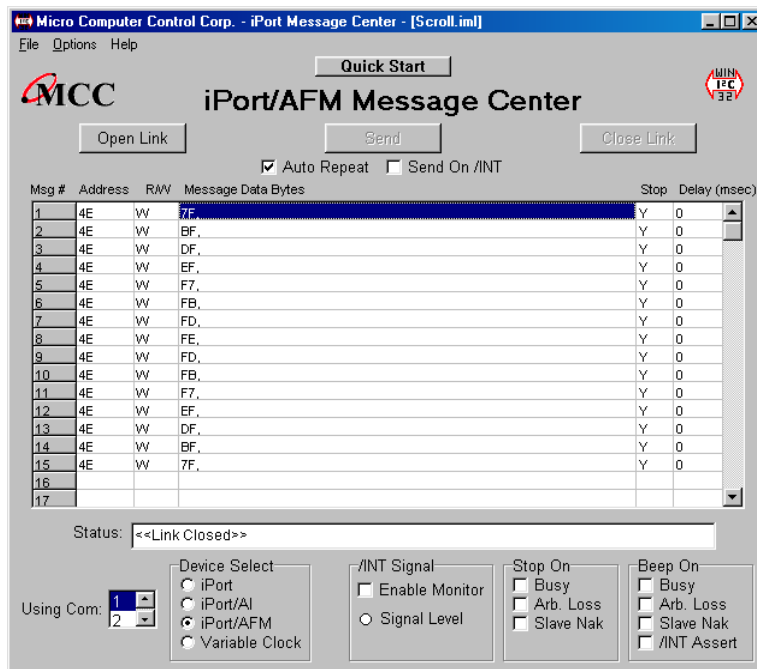

Main Application

The iPort Message Center allows a PC to become an I²C Master transmitter or receiving device, sending I²C messages between the PC and one or more I²C devices across an I²C Bus.

The iPort Message Center is designed to be a simple application for experimenting with I²C messages. It provides methods to:

1. Enter/Edit a list of I²C Master Transmit or Receive Messages.
2. Save and/or Load a list of I²C Master messages to/from disk.
3. Transmit the current list of I²C Master messages, with the option to auto-repeat upon completion, send on INT signal assertion (with INT signal supported adapters only), and beep or stop on special I²C Bus events.
4. Use command line arguments to automatically load, send, and save I²C messages from a batch file or another program.

Each I²C message can transfer up to 32 bytes of 8-bit data, with Repeated Start and Time Delay options.

4.1 Message Center Operations

Communicating with another device on the I²C Bus is easy. Just install the software as described in Section 3, then following these simple steps:

4.1.1 Starting the Message Center

Click, Start *Programs *iPort Utility Pack*iPort Message Center

4.1.2 Selecting the Adapter

Select the I²C adapter you are using by clicking the corresponding adapter image (see Opening Screen), or the Device Select checkbox (see Main Application Screen).

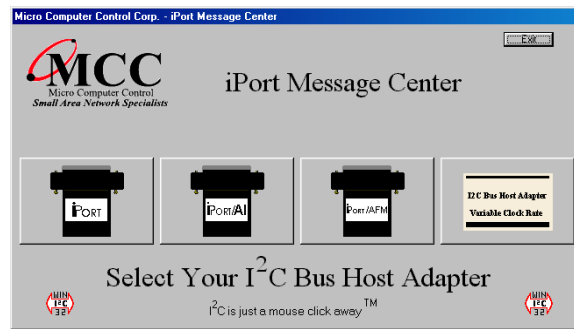

Opening Screen

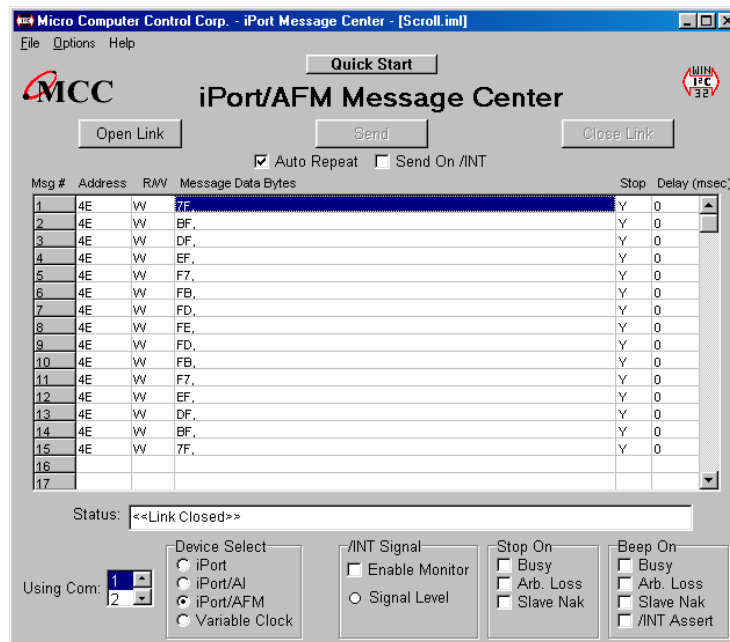

Main Application

4.1.3 Select the Communications Port

Use the “Using Com:” control to select the RS-232 communication port connected to the I²C adapter. Message Center supports USB and network connected local or remote RS-232 ports via the Windows Com driver.

4.1.4 Options Menu

Use the Options menu to override default Baud Rate and I²C Bus Clock rate settings. Default settings and options are adapter dependant.

4.1.5 Establish Adapter Communications Link

Establish the communications link to the I²C adapter by clicking the Open Link button.

The Message Center sets the adapter’s own I²C Slave address to 0xFE. Once the link has opened successfully, you are an active I²C node. I²C messages entered into the message spreadsheet can be transmitted upon request. If the link open is not successful, follow the on-screen directions. Make sure the communications port is working, is enabled in the Windows Device Manager, and is not being used by other software.

4.1.6 Entering or Editing I²C Messages

I²C messages can be entered with the Message Editor, or a previously recorded message list can be loaded from the File menu.

To enter or edit a message, open the “I²C Message Editor” screen by double clicking on a message row in the spreadsheet.

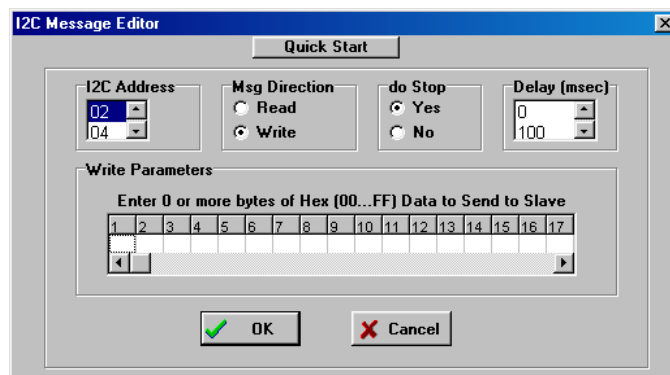

Use the I²C Message Editor to:

1. Set I²C Address.

The I²C Address is the I²C slave address of the slave device being addressed on the bus. All slave addresses are displayed as even numbers (00...FE), representing the 7 most significant bits of the 8-bit slave address transmitted on the bus (aaaa aaa0).

The I²C adapter automatically supplies the 8th, least significant, Read/Write bit when it sends the slave address across the bus. For master write operations, the Read/Write bit is always transmitted as a logical 0 (aaaa aaa0). For master read operations, the Read/Write bit is always transmitted as a logical 1 (aaaa aaa1).

Use the I²C Address control to set the slave address of the slave device you want to address on the bus.

2. Set Message Read/Write Direction.

As a bus master device, the I²C adapter can write data to, or read data from, any device on the bus. Use the Msg Direction control to specify if the current message is a master write, or master read, operation. Upon making your selection, additional Write or Read parameters appear.

3. Specify Repeated Start Messages.

I²C Bus communications support an operation called Repeated Start. In this operation, a message is sent across the bus beginning with a Start Condition, but without a Stop Condition at the end of the message. The next message sent across the bus begins with a Start Condition, in this case a Repeated Start.

An I²C Bus master, that successfully sends a message on the bus, owns the bus until that master sends a message with a terminating Stop Condition. The Repeated Start operation allows the bus master to retain control of the bus while sending one or more messages on the bus. This prevents other bus masters, in a multi-master system, from accessing the bus and interfering with message sequences.

The Message Center supports Repeated Starts with the doStop control. Sending an I²C message with doStop enabled will cause the message to be terminated with a Stop Condition. Sending an I²C message with doStop disabled will cause the message to end without a Stop Condition, allowing the next message to be sent with a Repeated Start.

4. Set Time Delay.

Message Center supports time delays after the completion of a message. Time delays can be used to synchronize or sequence bus messages with the activity of external devices.

5. Specify Write Data or Read Byte Count.

Enter the hexadecimal data you want to write to a slave receiver device, or the number of data bytes to read from a slave transmitter. Message Center supports up to 32 bytes of 8-bit data per message.

NOTE: The data you send may have special meaning to the receiving slave device, but to the Message Center, and the I²C adapter, message data has no special meaning. Consult your slave device's data sheet for details.

Click OK to accept the message and enter it into the spreadsheet.

Master Write messages display the message data in the spreadsheet. Master Read messages display 0xFF placeholders in the spreadsheet. Upon execution, actual data received from a slave transmitter replaces the placeholders in the message spreadsheet.

Repeat above steps for additional messages. The Message Center supports up to 32,000 messages in a list.

4.1.7 Inserting and Deleting Messages

You can insert a new message between existing messages by clicking once on a message below where you want to insert, then press the “Insert” key on your keyboard. The Message Editor also remembers the last message displayed, so double clicking on a blank spreadsheet row will allow you to copy a message. Delete a message by single clicking on the message row and pressing the “Delete” key on your keyboard.

4.1.8 Saving or Loading Message Lists

Message Center I²C message lists can be saved to, or loaded from, a disk file. To save the current message list, click File|Save on the menu bar. To open an existing message list, click File|Open List on the menu bar.

Message lists are maintained in ASCII text files (*.IML) that can be edited manually or created with a customer-developed program. See message list files for details.

4.1.9 Send the Message List

An I²C message list can be sent manually, or automatically in response to an INT signal assertion (with INT signal supported adapters only). To send the list manually, click the Send button on the main application screen. To send the list in response to an INT signal assertion (low), enable the “/INT Signal Monitoring” checkbox, and check the “Send on /INT” checkbox. The list will be sent each time the INT signal is asserted.

The Message Center also supports the repeated sending of a message list. If the Auto Repeat checkbox is checked, a message list will automatically repeat upon completion.

4.1.10 Special Event Handling

The Message Center supports the early termination of a message list, and beep on special events. See the “Stop On” and “Beep On” controls on the main application screen of available options.

4.1.11 Slave Not Acknowledging

If you get a “Slave Not Acknowledging” message in the Status window, this could indicate you have the wrong address in the I²C Destination Address, or the device is not answering to its address. Some slave devices temporarily stop acknowledging their address. Consult the slave device’s data sheet for details.

4.2 Command Line Arguments

The Message Center can be controlled via command line arguments. This feature allows the Message Center to be accessed from a batch file or another program.

Message Center Command Line Arguments	
Command	Description
iPort, iPort/AI, iPort/AFM, Variable	Specify I ² C adapter type.*
COM1...COM20	Specify RS-232 communication port.
BAUD19200, BAUD57600, BAUD115200	Set RS-232 Baud Rate.*
CLOCK12.5K, CLOCK23K, CLOCK86K, CLOCK100K, CLOCK400K, VCLOCK	Set I ² C Bus Clock Rate.*
Monitor/INT	Enable /INT Signal Monitor.*
StopOnBusy	Stop sending on I ² C adapter busy.
StopOnArbLoss	Stop sending on I ² C Bus Arbitration Loss.
StopOnNak	Stop on Slave Negative Acknowledgment.
BeepOnBusy	Beep on I ² C adapter busy.
BeepOnArbLoss	Beep on I ² C Bus arbitration loss.
BeepOnNak	Beep on Slave Negative Acknowledgment.
BeepOn/INT	Beep on /INT signal assert (low).*
AutoLoad	Load I ² C message list file.
AutoSave	Save I ² C message list file.
AutoOpen	Open link to I ² C adapter.
AutoSend	Send I ² C message list.
AutoExit	Exit after sending message list.

* Adapter specific commands. See command details below.

Command Line Syntax: `msgctr.exe AdapterType argument-list`

Example: `msgctr.exe iPort/AFM adctest01.iml AutoOpen AutoSend AutoExit`

4.2.1 Set Adapter Type

iPort	iPort (#MIIC-201)
iPort/AI	iPort/AI (#MIIC-202)
iPort/AFM	iPort/AFM (#MIIC-203)
Variable	Variable Clock (#MIIC-201-V)

The Adapter Type argument should be the first argument in the argument list as it controls the availability of other arguments. If the Adapter Type is not specified, the startup adapter selection screen will be presented.

4.2.2 Set RS-232 Communication Port

COM1 (Default)
COM2...COM20

Set the RS-232 communications port attached to the I²C adapter.

4.2.3 Set RS-232 Baud Rate

BAUD19200 (Default)
BAUD57600 (iPort/AFM ONLY)
BAUD115200 (iPort/AFM ONLY)

Set the RS-232 Baud Rate.

4.2.4 Set I²C Bus Clock Rate

CLOCK12.5K (iPort ONLY)
CLOCK23K (iPort/AFM ONLY)
CLOCK86K (iPort/AFM ONLY)
CLOCK100K (iPort, iPort/AI, iPort/AFM, Default)
CLOCK400K (iPort/AFM ONLY)
VCLOCK=nnnHz (Variable ONLY. nnn=451...57787)

Set the I²C Bus Clock Rate to the specified value. The default rate for the Variable Clock the adapter is 451Hz. The Variable Clock adapter does not support all rates within the specified range. The Message Center will adjust the specified rate to the nearest available supported rate.

4.2.5 Enable /INT Signal Monitor

Monitor/INT (on INT supported adapters only. Default=OFF)

Enable /INT signal monitoring.

4.2.6 Stop On Busy

StopOnBusy (Default=OFF)

Stop sending I²C messages if the adapter returns a "Busy" response to the host computer.

4.2.7 Stop On Arbitration Loss

StopOnArbLoss (Default=OFF)

Stop sending I²C messages if the adapter returns a "Bus Arbitration Loss" response to the host computer. Bus Arbitration Loss occurs when another I²C Bus master wins arbitration while the adapter is attempting to become a bus master.

4.2.8 Stop On Slave Negative Acknowledgment

StopOnNak (Default=OFF)

Stop sending I²C messages if the adapter returns a "Slave Not Acknowledging" response to the host computer. Slave Not Acknowledging occurs when the adapter is attempting to become a bus master and no slave device acknowledges the transmitted slave address.

4.2.9 Beep On Busy

BeepOnBusy (Default=OFF)

Generate a host computer beep if the adapter returns a "Busy" response to the host computer.

4.2.10 Beep On Arbitration Loss

BeepOnArbLoss (Default=OFF)

Generate a host computer beep if the adapter returns a "Bus Arbitration Loss" response to the host computer. Bus Arbitration Loss occurs when another I²C Bus master wins arbitration while the adapter is attempting to become a bus master.

4.2.11 Beep On Slave Negative Acknowledgment

BeepOnNak (Default=OFF)

Generate a host computer beep if the adapter returns a "Slave Not Acknowledging" response to the host computer. Slave Not Acknowledging occurs when the adapter is attempting to become a bus master and no slave device acknowledges the transmitted slave address.

4.2.12 Beep On /INT Assert

BeepOn/INT (on INT supported adapters only. Default=OFF)

Generate a host computer beep if the adapter returns a "/INT Signal Assert" response to the host computer. /INT Signal Assert occurs if /INT Signal Monitoring is enabled and a high to low transition is detected on the adapter /INT signal connector.

4.2.13 Load I²C Message List File

AutoLoad=filename

AutoLoad="file name"

filename.iml

"file name.iml"

Automatically open file with extension .IML and load messages into Message Center spreadsheet.

4.2.14 Saved I²C Message List File

AutoSave=filename
AutoSave="file name"

Automatically save message list to the specified file upon executing AutoExit. Use to save message data read from a slave transmitter device.

4.2.15 Auto Open

AutoOpen Auto Open Link to I²C Adapter

Open link to the adapter.

4.2.16 Auto Send

AutoSend Auto Send I²C Message List

Send I²C messages loaded with the AutoLoad command.

4.2.17 Auto Exit

AutoExit Auto exit after sending the message list.

Message Center will auto exit after sending the last message in the I²C message list.

5 iPort Message Manager

The iPort Message Manager supports I²C Master and Slave, Transmit and Receive activities for all MCC I²C Bus host adapters, allowing a PC to become an I²C Master or Slave device, transmitting or receiving I²C messages between the PC and one or more I²C devices across an I²C Bus.

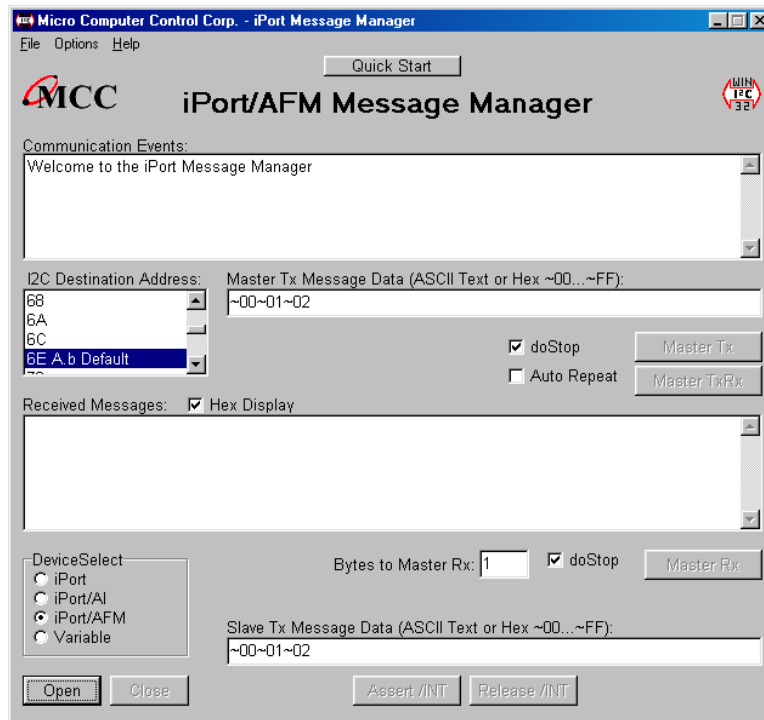

Main Application

The Message Manager is designed to be a simple application for experimenting with I²C messages. Message Manager provides methods to:

1. Set the I²C adapter's own I²C Slave address, General Call Enable, and other operating parameters.
2. Master Transmit ASCII text or Hex (00...FF) data to a specified I²C Slave Receiver device.
3. Master Receive data from a specified I²C Slave device.
4. Perform Master Read after Write operations.
5. Slave Transmit data to a requesting I²C Master device.
6. Display Master or Slave Receive data in hexadecimal or ASCII.
7. Display I²C Bus communication events.
8. Assert or release the INT signal (on supported adapters only).

5.1 Message Manager Operations

Communicating with another device on the I²C Bus is easy. Just install the software as described in Section 3, then following these simple steps:

5.1.1 Starting the Message Manager

Click, Start *Programs *iPort Utility Pack*iPort Message Manager

5.1.2 Select the Adapter

Select the I²C adapter you are using by clicking the corresponding adapter image (see Opening Screen), or the Device Select checkbox (see Main Application Screen).

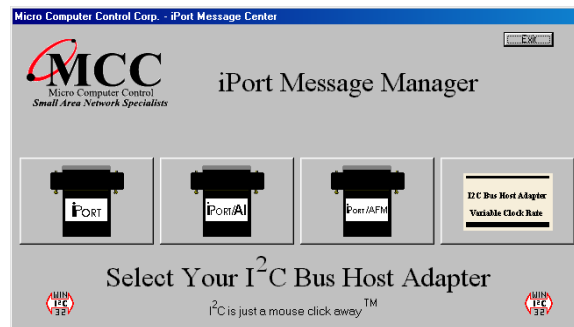

Opening Screen

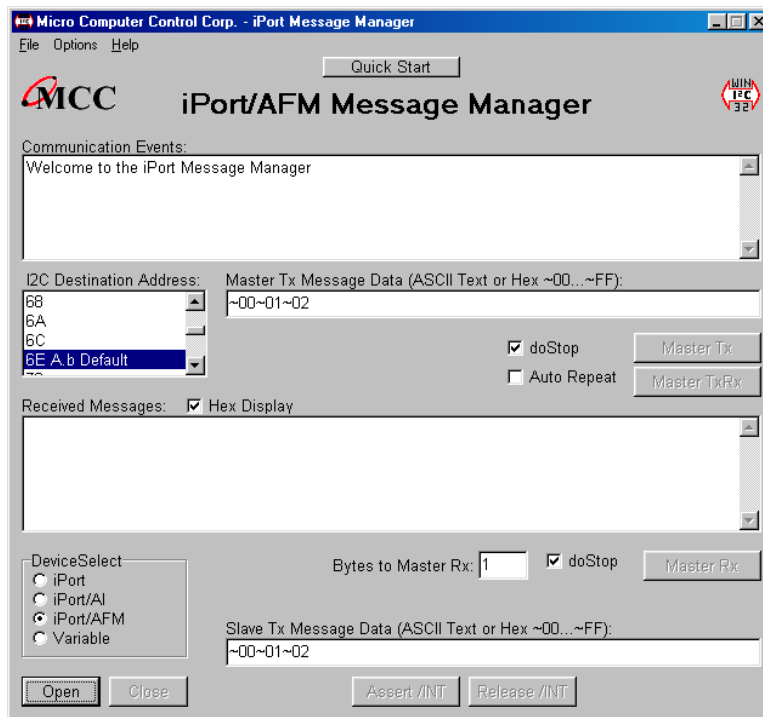

Main Application

5.1.3 Establish Adapter Communications Link

On the main screen, click the Open button to view the Set Up Screen. Three levels of setup options are available, Basic, Advanced, and Diagnostic. Only Basic setup is required.

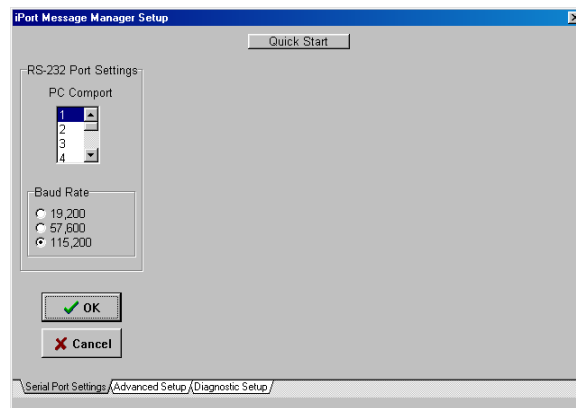

Basic Set Up Screen

5.1.3.1 Basic Setup

Use the “RS-232 Port Settings” control to select the RS-232 communication port connected to the I²C adapter. Message Manager supports USB and network connected local or remote RS-232 ports via the Windows Com driver.

Select from the list of available baud rates. Then click OK.

After a few moments, the Communication Events window on the Main Application screen should report “I²C Open Successful.”

If open is not successful, follow the on-screen instructions. Make sure the communications port is working, is enabled in the Windows Device Manager, and is not being used by other software. Additional communication port open information is available in the log file. See Diagnostic Setup options.

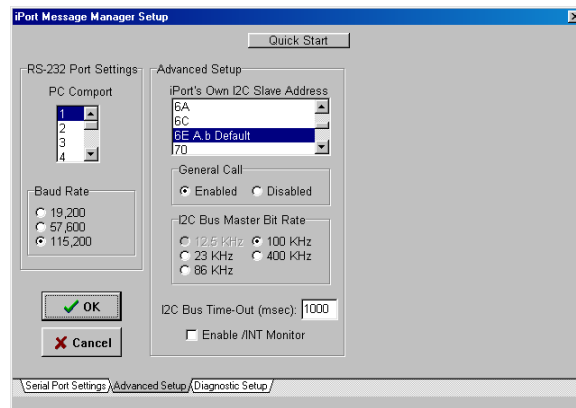

Advanced Set Up Screen

5.1.3.2 Advanced Setup

On the Advanced Setup screen you can set the following parameters:

Adapter's Own I²C Slave Address

Select the I²C adapter's own slave address. The adapter will acknowledge messages sent to this slave address. The default address is 0x6E.

General Call Enable

General Call Enable allows the I²C adapter to respond as a slave receiver to the I²C General Call Address (0x00). General Call is used by a master to broadcast an I²C message to multiple devices. The default value is enabled.

I²C Bus Master Bit Rate

Select I²C Bus speed during master operations. 100kHz is standard mode. 400kHz is fast mode. Available rates are I²C adapter dependant.

I²C Bus Time-Out

Specify how long the I²C adapter will wait before reporting an I²C Bus intra-byte time-out (0 = no time-out, 1 to 32767 milliseconds, iPort/AI fixed at 1 second).

Enable INT Signal Monitor (on supported adapters)

Enables monitoring of the INT signal state. INT state changes are reported in the

main screen Communications Events window.

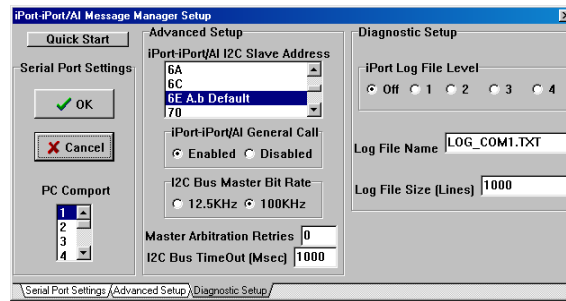

Diagnostic Set Up Screen

5.1.3.3 Diagnostic Setup (on supported adapters)

On the Diagnostic Set-up screen Message you can set the following parameters:

Log File Level

A log file is available to troubleshoot RS-232 communication problems with the selected communication port. The log file is an ASCII text file viewable with any text editor. Select logging level. Level 1 provides minimum information. Level 4 provides maximum information.

Log File Name

Specify a log file name. Unless a path is specified, the log file will be created in the current working directory.

Log File Size

Specify log file length in lines. The log file overwrites earlier entries upon reaching the specified number on lines.

5.1.4 Sending I²C Messages

5.1.4.1 Master Operations

5.1.4.1.1 Specifying the Destination Address

The Destination Address is the I²C slave address of the slave device being addressed on the bus. All slave addresses are displayed as even numbers (00...FE), representing the 7 most significant bits of the 8-bit slave address transmitted on the bus (aaaa aaa0).

The I²C adapter automatically supplies the 8th, least significant, Read/Write bit when it sends the slave address across the bus. For master write operations, the Read/Write bit is always transmitted as a logical 0 (aaaa aaa0). For master read operations, the Read/Write bit is always transmitted as a logical 1 (aaaa aaa1).

On the main screen, use the I²C Destination Address list control to set the slave address of the slave device you want to address on the bus.

5.1.4.1.2 Repeated Start Messages

I²C Bus communications support an operation called Repeated Start. In this operation, a message is sent across the bus beginning with a Start Condition, but without a Stop Condition at the end of the message. The next message sent across the bus begins with a Start Condition, in this case a Repeated Start.

An I²C Bus master, that successfully sends a message on the bus, owns the bus until that master sends a message with a terminating Stop Condition. The Repeated Start operation allows the bus master to retain control of the bus while sending one or more messages on the bus. This prevents other bus masters, in a multi-master system, from accessing the bus and interfering with message sequences.

The Message Manager supports Repeated Starts with the doStop checkbox. Sending an I²C message with doStop checked will cause the message to be terminated with a Stop Condition. Sending an I²C message with doStop unchecked will cause the message to end without a Stop Condition, allowing the next message to be sent with a Repeated Start.

5.1.4.1.3 Auto Repeat

The situation often arises, where you would like to automatically repeat a master message operation.

The Message Manager supports auto-repeat with the Auto Repeat checkbox. You can automatically repeat a master operation by checking the Auto Repeat control before clicking the Master Tx, Master Rx, or Master TxRx buttons. The master operation repeats until the Auto Repeat control is unchecked.

5.1.4.1.4 Master Transmitting Data

Specifying Master Tx Message Bytes

Master Tx Message Bytes is the ASCII or Hexadecimal data you want to transmit to a slave receiver device. With the Message Manager, entering master transmit data is easy. On the main application screen, click on the Master Tx Message Bytes box to open the data editor.

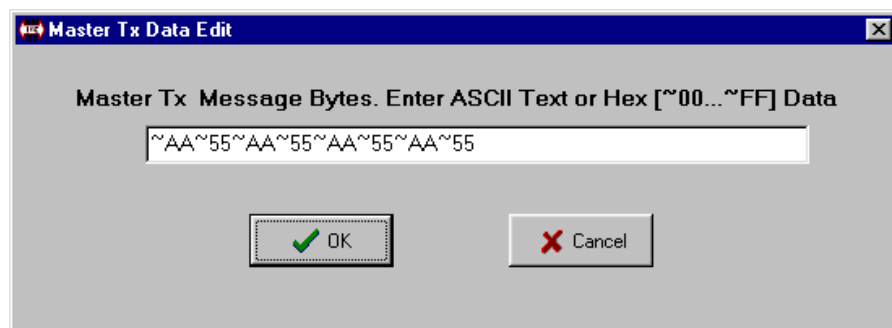

In the data editor, enter one or more ASCII text characters or hexadecimal data bytes. Each hexadecimal byte is entered as two ASCII-Hex characters (00 to FF) preceded by a tilde (~) character. ASCII text and hex data can be intermixed, as long as each hex byte is preceded by a tilde.

For example, to enter hex data bytes 0x00, 0x01, and 0x02, enter the characters ~00~01~02 into the text box.

Each iPort Message Manager I²C message can include up to 80 bytes of 8-bit ASCII binary data.

NOTE: The data you send may have special meaning to the receiving slave device, but to the Message Manager, and the I²C adapter, message data has no special meaning. Consult your slave device's data sheet for details.

Click OK to accept the data.

Sending Master Transmit Messages

Click the Master Tx button to write the specified Master Tx Data Bytes to the selected destination slave device. If Auto Repeat is checked, the message will automatically repeat upon completion.

The Communications Events window on the main screen should report “Master Tx Complete.” If this message does not appear, check the slave device address, connections, and power.

If you get a “Slave Not Acknowledging” message in the Communications Events window, this could mean you have the wrong address in the I²C Destination Address, or the device is not answering to its address. Consult your slave device’s data sheet for details.

5.1.4.1.5 Master Receive Data

Specifying Data to Read

On the lower part of the main screen, set the Bytes to MasterRx edit box to the number of bytes you want to read. For example: Set this to 1 to read a single byte. Click on the MasterRx button to read the data from the selected slave device.

Data received from the slave is displayed in the Received Messages text box on the main screen. The Communications Events window should report “Master Rx Transfer Complete.” If this message does not appear, check the slave device address, connections, and power.

If you get a “Slave Not Acknowledging” message in the Communications Events window, this could mean you have the wrong address in the I²C Destination Address, or the device is not answering to its address. Consult your slave device’s data sheet for details.

Negative Acknowledge Last Byte

On supported adapters, the doNak checkbox gives you the option to acknowledge, or negatively acknowledge, the last byte read from a slave device. Some Slave

Transmitter Devices require a negative acknowledgment on the final byte read from the slave device. I²C adapters not supporting this option automatically negatively acknowledge the last byte read.

5.1.4.1.6 Master Transmit and Receive

The Master TxRx button send a master write message with no Stop Condition, immediately followed by a Repeated Start master read message with Stop.

5.1.4.2 Slave Operations

In addition to performing I²C Bus master operations, the Message Manager can also perform I²C bus slave transmit and receive operations.

5.1.4.2.1 Slave Transmit Data

Slave transmit data is entered in the Slave Tx Message Bytes text box control on the main screen. Data in this text box is automatically sent to a requesting master upon receiving a slave transmit request.

Like Master Transmit data, Slave Transmit data is entered with the data editor. To enter data to be transmitted, click on the Slave Tx Message Bytes text box to open the data editor. See “Specifying Master Tx Message Bytes” section for data entry details.

5.1.4.2.2 Slave Receive Data

Data bytes received from a Master Transmitter are automatically displayed in the main application screen Received Message window. Received data is displayed in ASCII printable, or hexadecimal (~00 to ~FF) formats. Use the Hex-Display checkbox to force ASCII printable data to display in hexadecimal format .

6 Uninstalling iPort Utility Pack

Click, Start | Programs | iPort Utility Pack | uninstall.

Follow the on screen instructions.

Additional Information

For additional information on the I²C Bus, please refer to the following:

“What is I²C?”

www.mcc-us.com/I2CBusTechnicalOverview.pdf

“Frequently Asked Questions (FAQ)”

www.mcc-us.com/faq.htm

"The I²C and How to Use It"

www.mcc-us.com/i2chowto.htm

"80C51-Based 8-Bit Microcontroller" Data Handbook.

Philips Semiconductors, Tel. (800)227-1817

"I²C Peripherals for Microcontrollers" Data Handbook.

Philips Semiconductors

Appendix A - I²C Connector Information

Interface Connector and Plug Information

MCC uses two (2) different connectors and plug assemblies. We have found these parts to be compatible.

I²C Receptacle Connectors

Molex SEMCONN ACCESS.bus Receptacle Connector

Molex Part # 15-83-0064

AMP SDL (Shielded Data Link) Connectors for ACCESS.bus

AMP Part # 4-943197-1

I²C Plug Connectors

Molex SEMCONN ACCESS.bus Plug

Molex Part # 15-83-1564

AMP SDL (Shielded Data Link) Plug for ACCESS.bus

Bush	Amp Part # 520851-1
Ferrule	Amp Part # 520433-1
SDL (Shell)	Amp Part # 520461-1
SDL (Shell)	Amp Part # 520460-1
SDL	Amp Part # 4-520424-1

The following I²C Cables are available from MCC

MCC Part # CAB4	I ² C Interface Cable, 48inches (4ft)
MCC Part # CAB8	I ² C Interface Cable, 96 inches (8ft)
MCC Part # CAB16	I ² C Interface Cable, 192 inches (16ft)
MCC Part # CABCL	I ² C and SMBus Clip Lead Cable

